

Fiber Laser Cleaning Machine

1500W/2000W/3000W

Handheld and flexible



High efficiency
and perfect effect



Product Description

Laser cleaning equipment is a new generation of industrial surface cleaning laser system. It adopts the advanced laser source, laser optical scanners and control system to meet the requirements of metal surface cleaning process. It can be customized according to customer requirements to develop a dedicated cleaning system. Widely used for the surface laser degreasing, laser paint removal, laser removal of zinc, laser film removal, laser cleaning, such as coating, etc.

Product Size



Machine Front



Left Side of Machine



Top View of Machine



Machine Dimensional Drawing



3000W Machine Dimensional Drawing

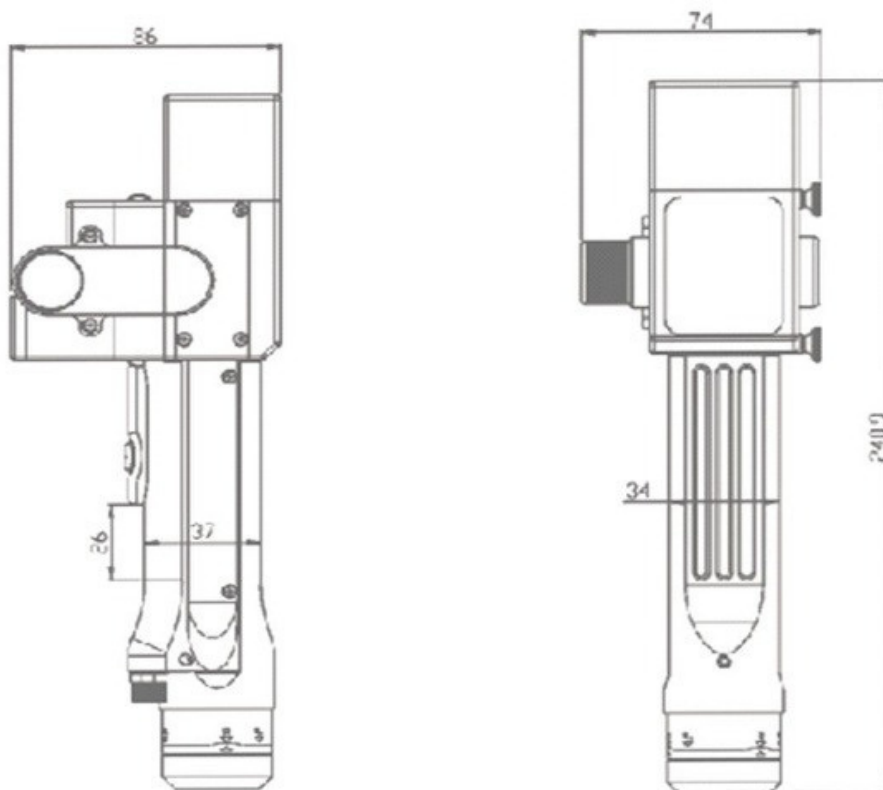

Product Parameter

Supply voltage	AC220V±10% 50/60Hz
Placement environment	Smooth, vibration and shock-free
Working temperature	10~40℃
Working environment humidity	<70%
cooling method	Water cooling
Applicable wavelength	1064nm(±10nm)
Applicable power	≤3000W
Collimation	D16*5-F60
Focus	D20*3.5
Reflection	20*15.2*T1.6
Protective mirror specifications	D30*T5
Maximum supported air pressure	15Bar
Focus vertical adjustment range	±10mm
Scan width-cleaning	F400-0~150mm
	F600-0~225mm
	F800-0~300mm
Weight	0.7kg

Power(W)	Material	Cleaning speed	Effective beam/cleaning range	Cleaning depth	Cleaning efficiency(cube/H)
1000	floating rust	25mm/s	150mm	20um	6
1000	paint	25mm/s	150mm	100um	4
1000	rust	25mm/s	150mm	120um	2.5
1500	floating rust	50mm/s	150mm	20um	15
1500	paint	50mm/s	150mm	100um	6
1500	rust	50mm/s	150mm	120um	4
2000	floating rust	50mm/s	300mm	20um	20
2000	paint	50mm/s	300mm	100um	8
2000	rust	50mm/s	300mm	120um	5
3000	floating rust	50mm/s	300mm	20um	30
3000	paint	50mm/s	300mm	100um	14
3000	rust	50mm/s	300mm	120um	9

● Cleaning Samples

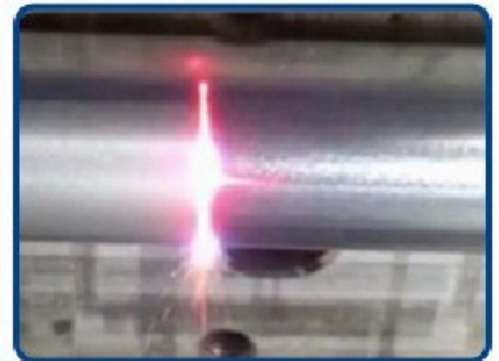
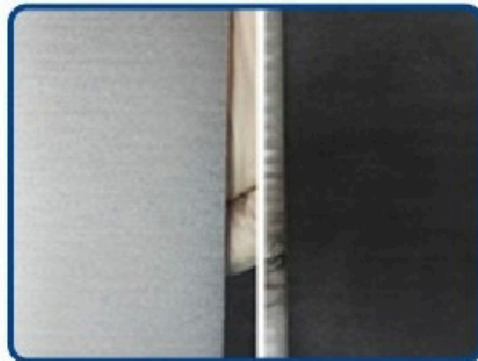
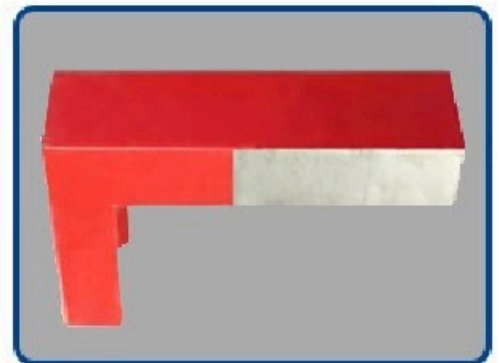
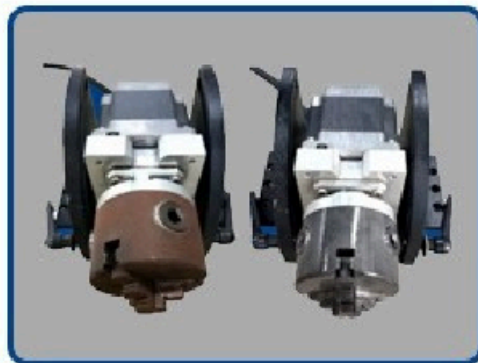
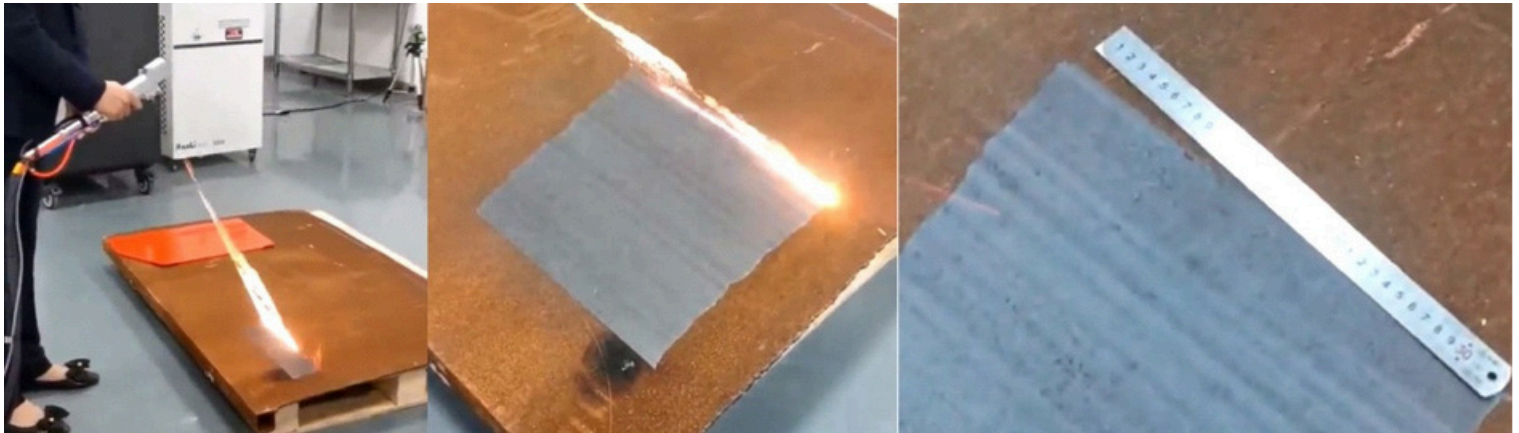

Product Detail Picture



Laser Cleaning Head



Adapt to various cleaning needs within 3000W, set a number of alarms, simple and flexible operation.

Control System



Simple operation, different fiber types and widths can be set.

Laser Source



Internationally famous laser source (Bwt/Max/Raycus/JPT), stable laser power, long life, good cleaning effect .

Water Cooling



Constant temperature cold water machine, condensation and rapid cooling, to ensure the constant temperature.

Cooling Air Inlet



Uniquely designed portable detachable dust-proof net, the air inlet is dust-proof and dust-proof, easy to disassemble and maintain.

Indicator Light



The indicator light has 3 colors.
Green: The machine is operating normally.
Yellow: The machine is working.
Red: The machine malfunction alarm.

Product Advantage Summary

01# Intelligent Design

The internal design is smart, the interactive control system expands the tolerance range of the processed parts and the width of the clean seam, it solves the disadvantage of small light spot and makes the clean seam better;



02# Bulk Dominance

The unique design of the outlet air knife can greatly increase the protective gas flow rate of the optical outlet and better prevent lens pollution.



03# Alarm Function

Monitor the status of the whole machine in real time, avoid problems in advance, facilitate troubleshooting and troubleshooting, and ensure the stable operation of the cleaning head.

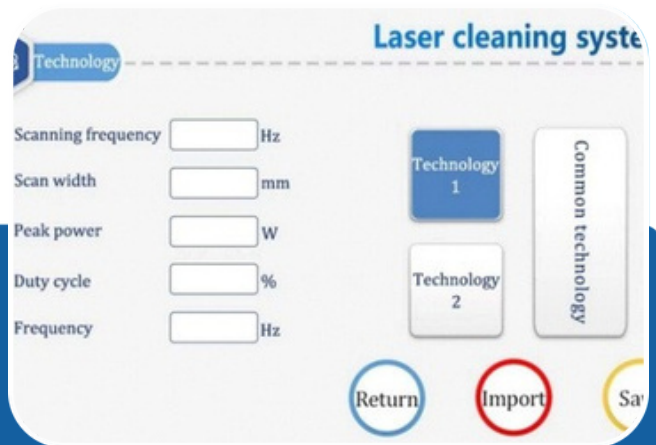

04# Cleaning Advantage

Fast speed, no consumables, no cleaning marks, no discoloration, no need for later polishing;



Package Weight And Size

GW:163KG

1000W/1500W/2000W

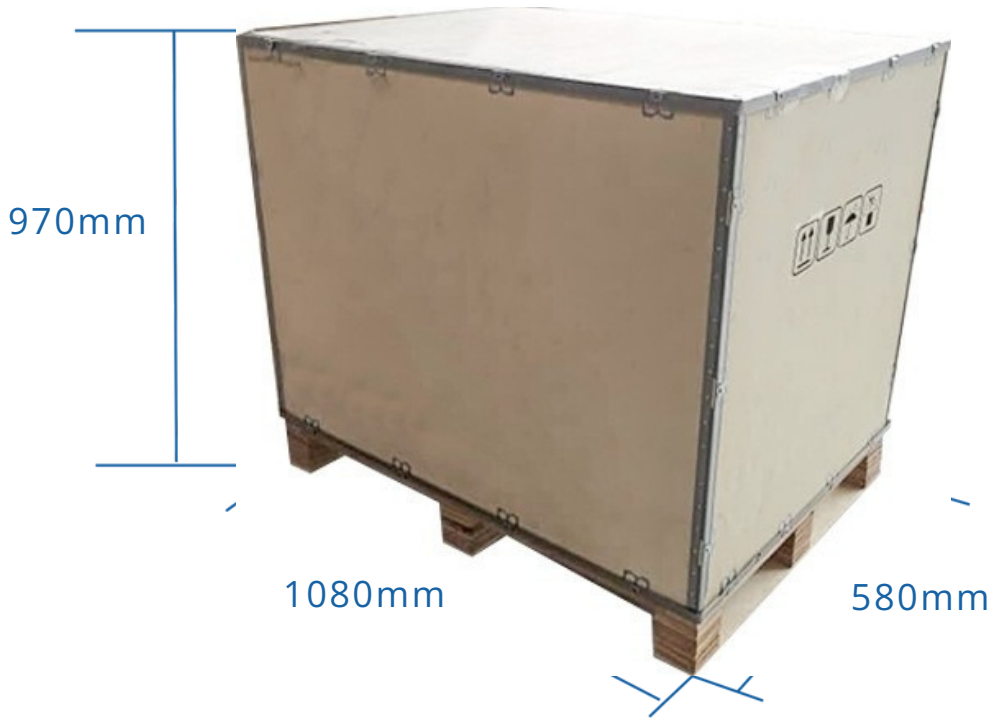



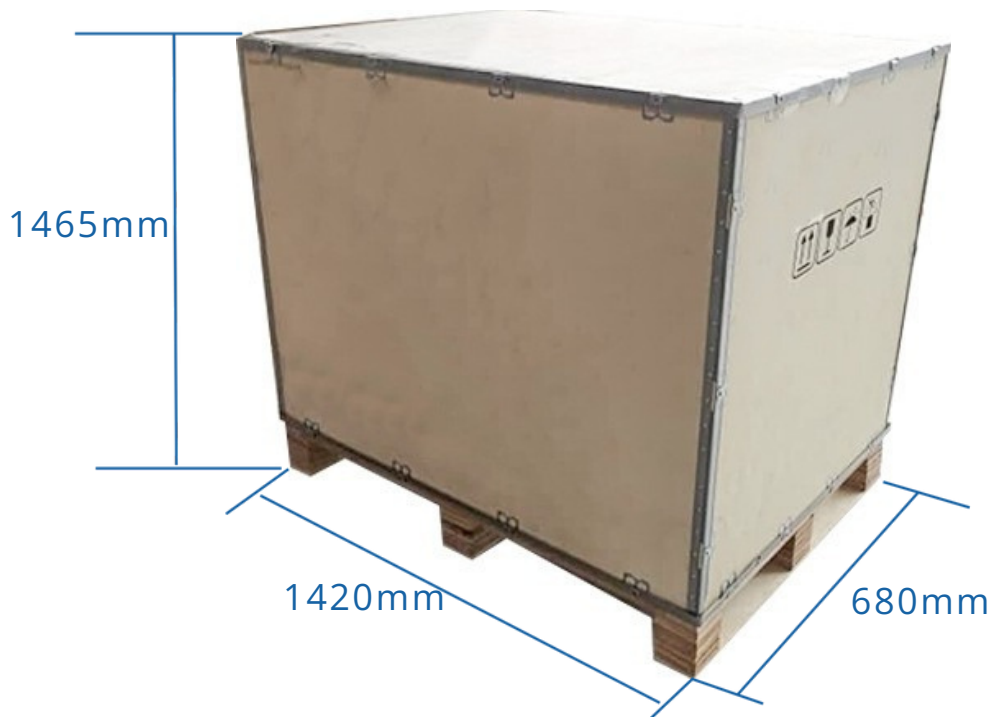

GW:272KG

3000W



SUP22C

Name	Quantity	Picture
Protective lens(30*5)	5PCS	
Goggle	1PCS	
Glove	1PCS	
Toolbox	1PCS	
Cleaning focusing len(F400)	1PCS	

DATASHEET



 +9971528706773

 mks@gogroupglobal.com

 www.gogroupglobal.com